

Sentinel A1 – Assembly instructions for use

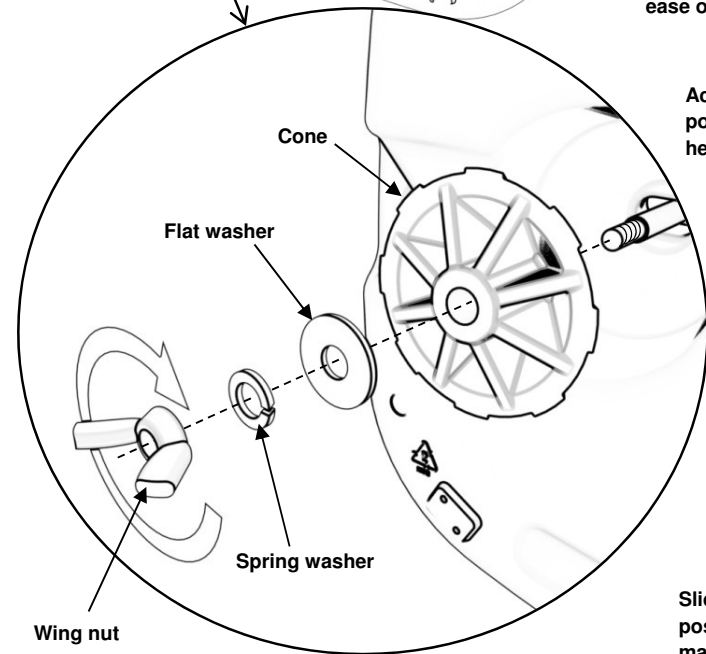

IMPORTANT!
SIGN IS AT RISK OF FALLING OVER IF BASE IS NOT FULLY FILLED WITH WATER. RESPONSIBILITY RESTS WITH THE USER.

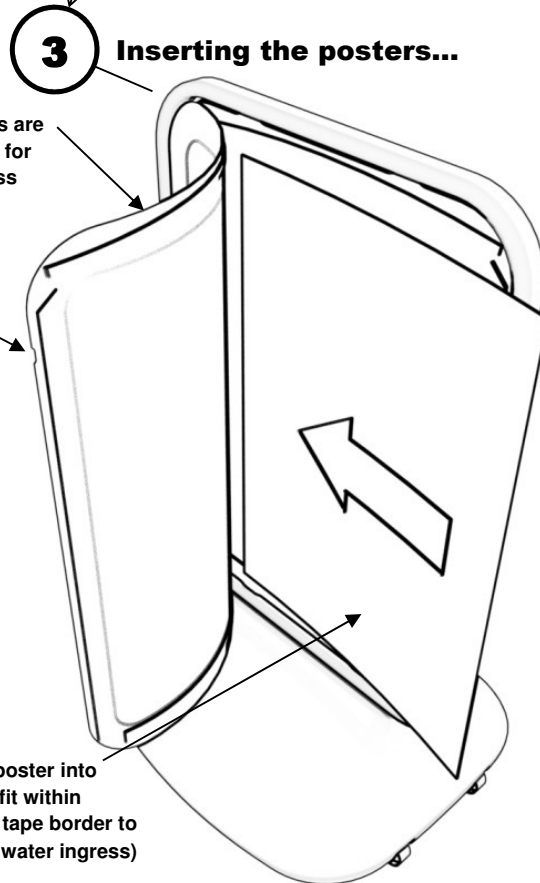
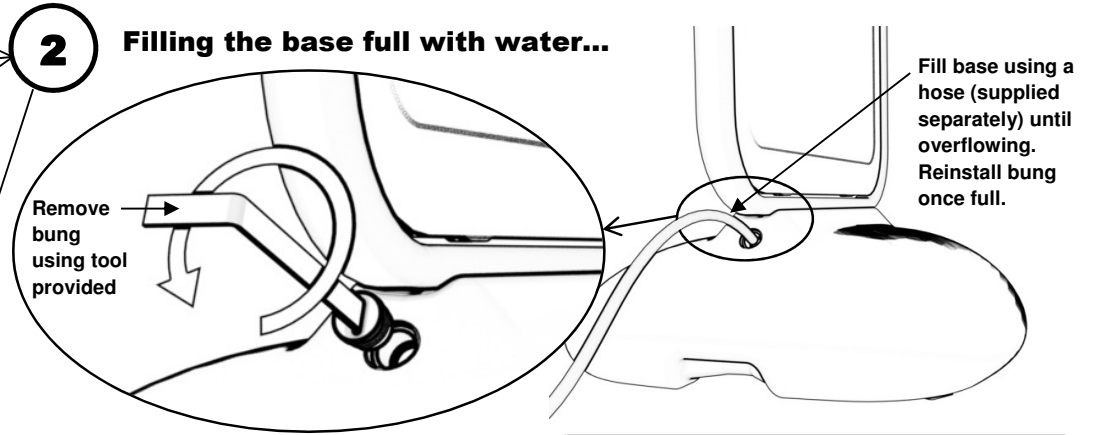
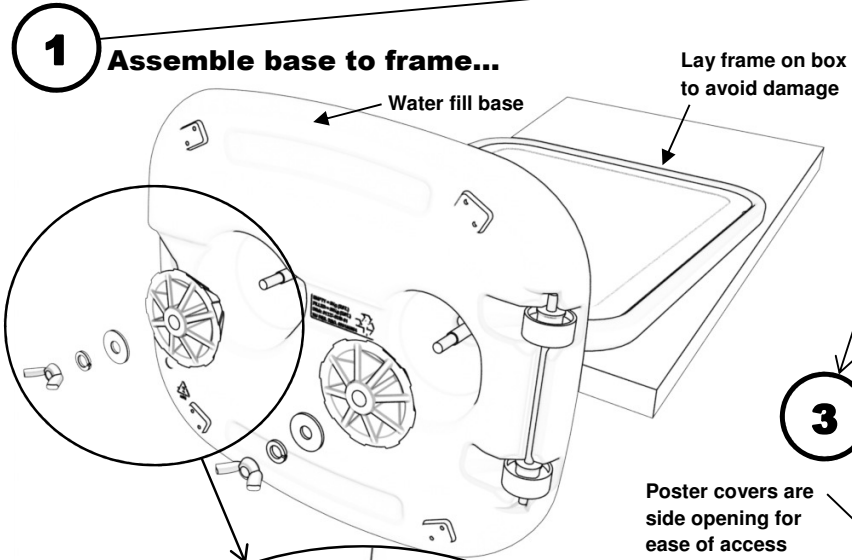
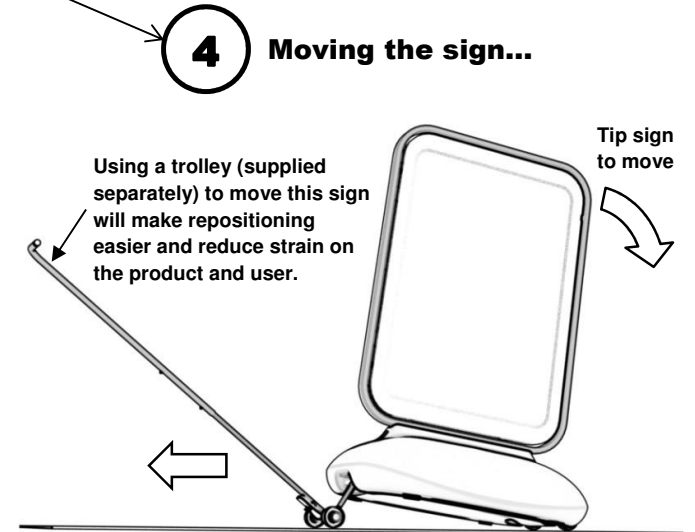

S-0270-01 (CRN2018-155)